

DETALIU PODET CORUGAT
ACCES
SCARA 1:50

SECȚIUNE LONGITUDINALĂ
A - A

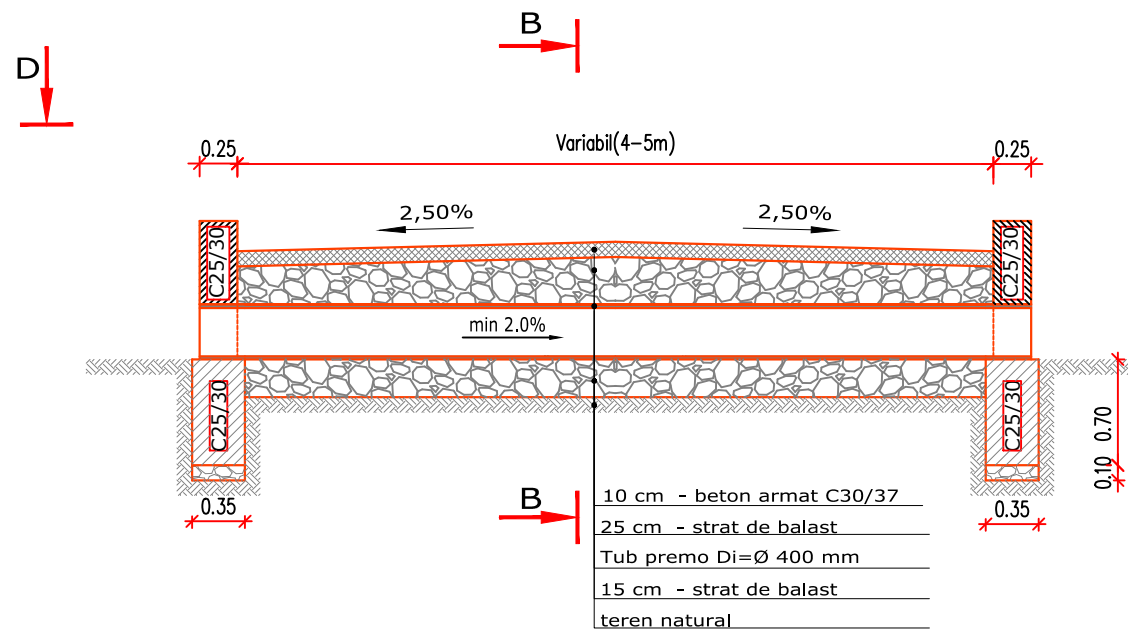

SECȚIUNE
B - B

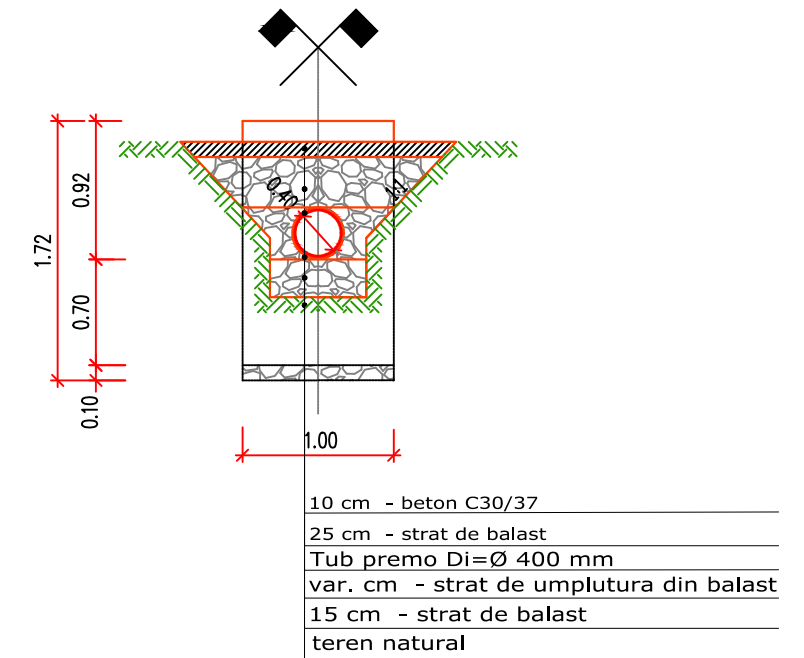

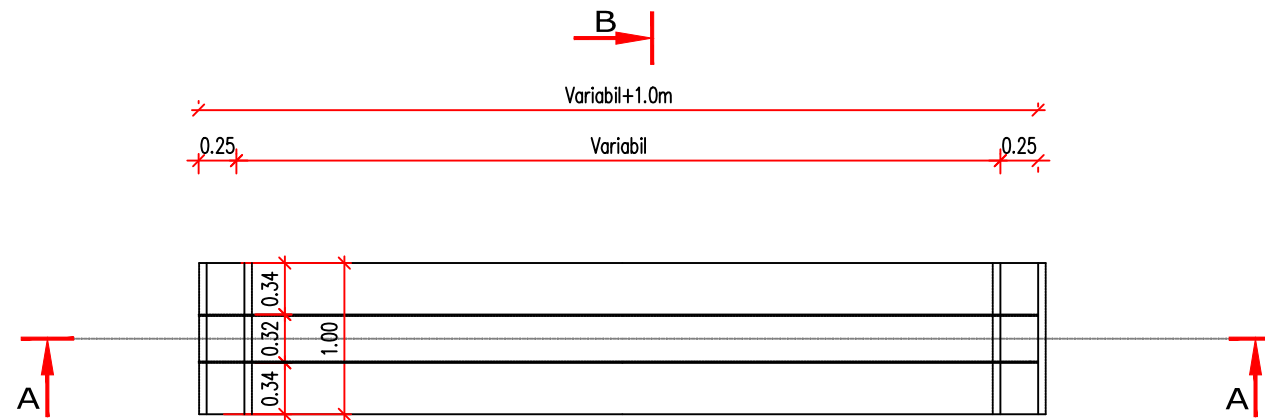

VEDERE ÎN PLAN
D - D

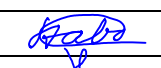

CERINTE DE CALITATE

- Beton: C 30/37
- Oțel: BST 500B
- Clasa de expunere: XF2+XC3+XD1
- Raportul maxim: A/C 0.50
- Dozaj minim de ciment: 340 kg/m³
- Tipul de ciment: CEM II A - S 32.5 N sau R
- Stratul minim de acoperire cu beton: 2.5 cm

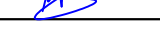
VERIFICATOR / EXPERT	NUME	SEMĂTURĂ	REFERAT/EXPERTIZĂ NR./DATA		
Proiectant:	SC PROIECT-CONSTRUCT REGIUNEA TRANSILVANIA SRL <small>Oradea, Str. Matei Corvin nr. 290, Tel: 0360/566484, Fax:0359/815839</small> <small>CUI: RO23719545, Nr. înreg. J5/1405/2013</small> <small>E-mail: proiecttransilvania@yahoo.com</small> <small>Site: www.proiecttransilvania.ro</small>		 <small>SISTEM DE MANAGEMENT CERTIFICAT</small> <small>ISO 9001:2015 / ISO 14001:2015</small>	Beneficiar: CONSILIUL JUDETEAN TIMIS Adresa: Bulevardul Revoluției din 1989 nr.17, Timisoara, judetul Timis	PROIECT NR. 27/2023
SPECIFICAȚIE	NUME	SEMĂTURĂ	SCARA	Titlu proiect:	
Șef proiect	Ing. Szabo O.		1:50	"Lotul 1 - Modernizare drum interjudetean DJ 684 pe traseul DN 68A(Cosava) - Tomesti - Luncanii de Jos" Sector 2 - km 8+800 - km 19+189	
Proiectat	Ing. Antal C.		DATA	Titlu planșă:	
Desenat	Ing. Szabo Laszlo		05.2025	PODET CORUGAT DE ACCES D=400 MM	
				PLANȘA NR. DET2	